



HEINRICH KIPP WERK



QUICKFINDER

Clamping technology

Standard elements

Operating parts



# LIST OF CONTENTS



+49 7454 793 - 0



+49 7454 793 - 7982



sales@kipp.com



www.kipp.com

QUICKFINDER 2

---

## COMPANY

Manufacturing expertise: TRUST IN KIPP 4

Locations 6

---

PRODUCT LINES 8

---

PRODUCT SPECTRUM 9

---

OPERATING PARTS I 11

STANDARD ELEMENTS

---

CLAMPING TECHNOLOGY 55

---

SPECIAL SOLUTIONS 71



Reg. No. 002081 QM



## SERVICE HOURS

MONDAY – THURSDAY 7.00 am – 5.30 pm

FRIDAY 7.00 am – 3.30 pm

# QUICKFINDER

Quick overview of product categories



The handy KIPP Quickfinder leads quickly and assuredly to the correct products. Clearly summarised in categories, you receive a compact overview of dimensions, materials, versions and finishes.

HEINRICH KIPP WERK has highly trained customer service staff and expert technical advisers with many years of experience.

We can be reached during office hours at the telephone number +49 7454 793-0.





Quick overview  
of **product categories**



**Pictograms** refer  
to the product groups  
in the KIPP catalogues



The most important  
**characteristics** as well as  
possible uses are quickly visible

## QUICKFINDER

### ! CAD data

A free download of CAD libraries is offered at [www.kipp.com](http://www.kipp.com). You receive 2D and 3D formats online, in the common formats, which you can implement directly into the planning and production process.

# TRUST IN KIPP

Manufacturing expertise with family tradition





**F**or 100 years, HEINRICH KIPP WERK has been a quality partner to industry. We offer a comprehensive product spectrum with more than 42,000 elements in the core sectors of clamping technology, standard elements and operating parts.

We produce in our machine shop, located in Germany. This guarantees rapid response times and short logistics routes. Customers appreciate our production resources and many years of development experience.

Reliability. Longevity. Sustainability. This is what our owner-managed company has stood for from the very beginning.



*N. Kipp*      *Heinrich Kipp*

Nicolas Kipp

Heinrich Kipp

# LOCATIONS

HEINRICH KIPP WERK is located in Germany. This is where the production takes place and the fully automated, high-performance logistics centre is located. Internationally, the corporate group is currently represented with 9 owned subsidiaries.

International orientation is a company goal. In addition, more than 50 permanent agencies service all major international markets. Some of these have been your local contact partner for decades. Further information at [www.kipp.com](http://www.kipp.com)



## HEINRICH KIPP WERK KG

Heubergstrasse 2  
72172 Sulz am Neckar  
Germany  
[www.kipp.com](http://www.kipp.com)



## KIPP FRANCE SAS

6, rue des Frères Caudron  
78140 Vélizy-Villacoublay  
France  
[www.kipp.fr](http://www.kipp.fr)



## KIPP ITALIA SRL

Via Gaudenzio Ferrari, 21 B  
21047 Saronno (VA)  
Italy  
[www.kipp.it](http://www.kipp.it)



## KIPP NEDERLAND BV

Willem Dreeslaan 251  
2729 NE Zoetermeer  
Netherlands  
[www.kippcom.nl](http://www.kippcom.nl)



## HEINRICH KIPP GmbH

Traunufer Arkade 1  
4600 Thalheim bei Wels  
Austria  
[www.kipp.at](http://www.kipp.at)



## KIPP POLSKA Sp. z o.o.

ul. Ostrowskiego 7  
53-238 Wrocław  
Poland  
[www.kipp.pl](http://www.kipp.pl)





**KIPP SCANDINAVIA AB**

Zakrisdalsvägen 26  
653 42 Karlstad  
Sweden  
[www.kipp.se](http://www.kipp.se)



**KIPP SCHWEIZ AG**

Benzburweg 18A  
4410 Liestal BL  
Switzerland  
[www.kipp.ch](http://www.kipp.ch)



**KIPP CZ s.r.o.**

Vienna Point 2  
Václavská 188/119d  
Dolní Heršpice, 619 00 Brno  
Czech Republic  
[www.kipp.cz](http://www.kipp.cz)



**KIPP Inc.**

4305 N. Roosevelt Rd.  
Stevensville, MI 49127  
USA  
[www.kippusa.com](http://www.kippusa.com)

# PRODUCT LINES

## **NOVO grip**



Our NOVO grip product line is the classic in the plastic sector. Well thought out in every detail. Sophisticated design, easy-grip form and efficient price/performance.

## **NATURE grip**



Our NATURE grip product range is environmentally friendly and produced from bioplastic. It consists entirely of renewable raw materials.

## **MEDI grip**



MEDI grip is suitable for areas with high hygienic requirements. The operating parts contain micro-silver, which has an antibacterial effect on the surface.

## **FEATURE grip**



With the FEATURE grip product line, KIPP offers smart components and solutions that provide information, are network-capable, and perfect for digitisation in Industry 4.0.

## **NOVOnox hygienic**



The stainless steel products from the NOVOnox hygienic line target the foodstuff, pharmaceutical, chemical and packaging sectors – according to the standard hygienic DESIGN.

## **SYMPA touch**



It's in the name. SYMPA touch, our product line for maximum ergonomics. The soft and simultaneously anti-slip material sits perfectly in the hand.

## **ESD**



These products are made from an electrically conductive plastic. They can therefore be used in ESD-secure areas, where electrostatic sensitive components can often be found.

## **19" TECHNOLOGY**



Grips, rails and standard elements suitable for 19 inch systems. Compatible for applications in the IT sector, event technology, laboratories and computer centres.

## **ACCESSORIES alu profiles**



The solution for connecting, clamping and holding aluminium profiles. All components perfectly match conventional profiles with 8 mm or 10 mm slot widths.

## **STAINLESS STEEL**



Products marked with this symbol are made from stainless steel. The predominant material used here is the austenitic alloy 1.4305.



OPERATING PARTS | STANDARD ELEMENTS



CLAMPING TECHNOLOGY



SPECIAL SOLUTIONS







OPERATING PARTS | STANDARD ELEMENTS

## Clamping levers



### Product versions:

- Thread Ø: M5–M12
- Thread type: Internal thread, external thread
- Thread length: 10–90 mm
- Thread depth: 9–27 mm
- Grip length: 37–126 mm
- Materials: Steel, stainless steel, die-cast zinc, plastic
- Versions: With push button, with protective cap, Hygienic USIT®, flat, antistatic, antibacterial, 2-component, ECO, with thrust pad, ergonomic, non-adjustable
- Colours: Black, grey, red, green, yellow, blue, orange, silver, bright



### Product description:

Clamping levers are intended for manual alignment with fixation tasks and clamping applications. There is a lot of variation in this product group due to the range of designs, materials and colours available. These classic elements can be used in a wide variety of applications. However, they are most suitable for machine and plant construction, and in toolmaking.



## Cam levers



### Product versions:

- Thread Ø: M3–M10
- Thread type: Internal thread, external thread
- Thread length: 10–50 mm
- Height: 13–29 mm
- Grip length: 41.7–110 mm
- Clamping force: 1.5–8 kN
- Materials: Stainless steel, steel, plastic, cast aluminium
- Versions: Adjustable, quick lock, elastomer lock
- Colours: Black, red, bright



### Product description:

Cam levers are ideal for quick fixation. The products are available in various materials and colours. They are used in machine and plant construction, in toolmaking, and in medical and rehabilitation technology.





## Tension levers / flat tension levers



### Product versions:

Thread Ø:	M6–M24
Thread type:	Internal thread, external thread
Thread length:	15–90 mm
Thread depth:	14–27 mm
Materials:	Stainless steel, steel
Versions:	Safety function, flat
Surfaces:	Black, bright

### Product description:

Tension levers are used for simple clamping tasks. The threaded insert is available in different versions and sizes. Tension levers are used in machine and plant construction.



## Knurled nuts / knurled screws / knurled knobs



### Product versions:

Thread Ø:	M3–M12
Thread type:	Internal thread, external thread
Thread length:	10–60 mm
Thread depth:	5–22 mm
Outside diameter:	12–63 mm
Materials:	Stainless steel, free-cutting steel, carbon steel, thermoplastic, Duroplast, biopolymer (beech), aluminium
Versions:	Quick-acting, flat, high, low, antistatic, for screws
Colours:	Black, bright, black-grey, light grey, yellow, orange, grey, red

### Product description:

Nuts, screws and knurled knobs are particularly suitable for manual positioning and clamping. They enable smooth, tool-free assembly. The various designs, thread sizes and materials can be used in a whole host of applications in machine and plant construction as well as toolmaking.





## Palm grips / star grips / clamping grips



### Product versions:

Thread Ø:	M4–M20
Thread type:	External thread, internal thread, tapped through, blind, counterbored
Thread length:	10–60 mm
Thread depth:	7.5–36 mm
Outside diameter:	25–105 mm
Materials:	Aluminium, stainless steel, grey cast iron, Duroplast, thermoplastic, biopolymer, fibreglass reinforced plastic
Versions:	Cap, locating brush, quick-acting, high collar, elongated hub, safety cable, antibacterial, flat, high, soft, ergonomic, tapped bush
Colours:	Bright, black, slate grey, light grey, red, yellow



### Product description:

Clamping grips, star grips and palm grips are primarily used as retaining and fastening elements for manual tasks. An ergonomic design is among the key features of these products. They come in a range of different materials, sizes and shapes, allowing them to be used in applications such as machine construction and the chemical industry.



## Knobs



### Product versions:

Thread Ø:	M2–M12
Thread type:	External thread, internal thread
Thread length:	10–20 mm
Thread depth:	4–20 mm
Outside diameter:	14–63 mm
Materials:	Steel, stainless steel, aluminium, thermoplastic, biopolymer (beech)
Versions:	Antistatic, antibacterial, high collar, low collar, blue passivated, bright
Colours:	Black, red, yellow, light grey, black-grey, slate grey, graphite black



### Product description:

Knobs can be used as a clamping, retaining and fastening element. They are available in various designs and thread sizes. Knobs are primarily used for manually adjusting assemblies, machines or aggregates.





## Wing grips / T-grips / grip nuts / grip screws



### Product versions:

Thread Ø:	M3–M12
Thread type:	External thread, internal thread
Grip length:	22–90 mm
Thread length:	8–50 mm
Materials:	Stainless steel, polyamide, thermoplastic, steel, biopolymer (beech)
Versions:	One-sided, Miniwing, for screws, antibacterial, T-grip, lock grip
Colours:	Black, bright, red, yellow, green, blue, white, grey, slate grey, graphite black

### Product description:

Wing grips and T-grips as well as grip nuts and screws are used as clamping, retaining and fastening elements in various applications. They are standard elements in machine and plant construction and function as manual controls on assemblies, machines or aggregates.



## Ball knobs / spherical knobs



### Product versions:

Thread Ø:	M4–M12
Thread type:	External thread, internal thread
Thread length:	10–40 mm
Thread depth:	6–23 mm
Outside diameter:	16–50 mm
Materials:	Duroplast, thermoplastic, stainless steel, aluminium, biopolymer (beech)
Versions:	Rotating, tapped bush
Colours:	Black, black-grey, light grey, red, yellow, polished

### Product description:

Ball knobs and spherical knobs are used as clamping, retaining and fastening elements. They are primarily used for manually adjusting assemblies, machines or aggregates.





## Torque grips



### Product versions:

Thread Ø:	M5–M12
Thread type:	External thread, internal thread
Thread length:	30–60 mm
Thread depth:	5–13 mm
Outside diameter:	26–80 mm
Materials:	Thermoplastic
Colours:	Black, black-grey, light grey, red, yellow

### Product description:

Torque grips can also be used as clamping, retaining and fastening elements. They are primarily used for manually adjusting assemblies, machines or aggregates. Depending on the version, the torque is signalled via clicking or free turning.



## Pull handles



19"



### Product versions:

Fastening hole:	Ø 5.5–Ø 9 mm / M3–M10
Hole spacing:	93.5–236 mm
Length:	98.5–218 mm
Load bearing capacity:	300–3700 N
Materials:	Stainless steel, stainless steel investment cast, round aluminium, oval aluminium, aluminium profile, aluminium, thermoplastic, SEBS, ductile iron, Duroplast, polypropylene, round steel, steel
Versions:	Angled, soft inner face, high temperature resistant, antibacterial, antistatic, with/without end cap, with/without baseplate, oblique, oval, round, fold-down, counterbored, threaded insert, compact, adjustable, Hygienic USIT®
Colours:	Black, matt black, black-grey, basalt grey, light grey, bright, orange, ruby red

### Product description:

Pull handles are particularly suitable for opening and closing covers, panels or hoods. What makes ours special is the fact that they have good haptics, are exceptionally stable and have an ergonomic design. The product range offers a variety of sizes, shapes, materials and colours.





## Recessed handles / recessed fold-down handles

19"



### Product versions:

Length:	90–170 mm
Height:	40–79 mm
Load bearing capacity:	250–1000 mm
Materials:	Aluminium profile, die cast aluminium, thermoplastic, stainless steel, polyamide
Versions:	Fold-down, clip-in
Surfaces:	Black, light grey, natural colour anodised, bright

### Product description:

Recessed handles can be installed quickly and easily due to their ergonomic shape. The fold-down version enables installation even in places where only a shallow installation depth is available. Recessed handles are available in a range of versions and colours. Recessed fold-down handles are ideally suited to crates and lids.



## Ledge handles



### Product versions:

Fastening hole:	M4–M8
Hole spacing:	30–120 mm
Load bearing capacity:	200–1000 mm
Materials:	Profile aluminium, profile stainless steel
Versions:	Natural colour anodised, black

### Product description:

Ledge handles are extremely versatile and are used as elements for opening and closing covers, panels and hatches. They are available in various versions, designs and materials. Ledge handles are used in machine and plant construction as well as toolmaking.





## Handwheels



**Product versions:**

- Fastening hole: 8–43 mm
- Outside diameter: 80–500 mm
- Materials: Aluminium, Duroplast, thermoplastic, grey cast iron, polyamide, stainless steel
- Versions: Rotating / fixed / no handle, straight wheel rim, pre-drilled, reamed hole, fold-down handle, safety cylinder grip, with/without key way
- Colours: Black, black-grey, green, red, yellow, blue, bright

**Product description:**

Handwheels are used to position and adjust shafts and spindles manually. They are predominantly used as control elements in machine and plant construction. They are also suitable for opening and closing valves in hydraulic and steam aggregates.



## Grips for handwheels



**Product versions:**

- Thread Ø: M3–M16
- Thread type: Internal thread, external thread
- Thread length: 6–70.5 mm
- Thread depth: 7.5–26 mm
- Materials: Steel, stainless steel, aluminium, Duroplast, thermoplastic
- Versions: Fixed cylinder grips, rotating, fold-down, auto-return safety cylinder grips, oval, taper grips, machine handles, moulded thread
- Surfaces: Black, black-grey, bright

**Product description:**

Machine handles, cylinder grips, taper grips and ball grips are used in a wide variety of applications.





## Position indicators



### Product versions:

Receiving hole:	Ø 10–Ø 30 mm
Width:	22–48 mm
Height:	33–71 mm
Length:	26–38.8 mm
Materials:	Plastic
Versions:	Programmed, not programmed
Colours:	Orange, black

### Product description:

Position indicators enable the precise measurement of the travel path. Despite their small size, they are extremely precise. They are especially suitable for small shaft diameters. Position indicators are available as either mechanical or digital indicators.



## Crank handles



### Product versions:

Bore Ø:	7–17, AF (square) 10–22
Height:	13–44 mm
Materials:	Aluminium, steel, stainless steel, thermoplastic, cast iron
Versions:	Rotating, fold-down
Surfaces:	Black, black-grey, bright, galvanised

### Product description:

Crank handles are highly recommended for longer travel paths. They are fastened axially or radially using cross-pinning or a socket head screw.





## Quarter-turn locks



### Product versions:

Actuator:	Square socket, slot, double lug, T-grip, L-grip
Tongue length:	25–60 mm
Tongue spacing:	4.5–74 mm
Wall thickness:	5–40 mm
Materials:	Die-cast zinc, steel, stainless steel, plastic, plastic coated, Duroplast
Versions:	Small/long version, lockable, stepped cam, variable compression, flat, sterile area, free-turning
Colours:	Black, red, bright

### Product description:

Quarter-turn locks are locks for hatches, control cabinets, steel cabinets and machine doors. They are sturdy and have an optional cylinder lock. They are used in control cabinet construction, in all transport sectors, as well as in service and logistics vehicles. If required, quarter-turn locks can be installed pre-assembled. In most cases, the tongues can be flexibly combined with other quarter-turn locks.



## Edge protection profiles



### Product versions:

Width:	8–11 mm
Height:	10–22 mm
Length:	2000–50000 mm
Materials:	PVC, EPDM, EPDM foam rubber
Versions:	With integrated steel retaining strip / steel wire core
Colours:	Black

### Product description:

Edge protection profiles are used in machine construction to cover and decorate the sharp edges of sheet metal. They are installed quickly and easily by pressing on by hand. No extra adhesive or fastening material is required. The optional EPDM foam rubber also provides a seal against moisture, dust and dirt.



## Accessories for quarter-turn locks



### Product versions:

Materials: Plastic thermoplastic, die-cast zinc  
 Versions: Dust cap, opening grip, key  
 Surfaces: Black, chromed

### Product description:

Our extensive range of quarter-turn locks are supplemented by additional accessories such as opening grips, keys and dust caps which provide additional protection if required.



## Hinges



### Product versions:

Width: 28–240 mm  
 Type of fastening: Weldable, fastening holes, fastening screws, fastening nuts, bushes, elongated holes  
 Materials: Thermoplastic, aluminium, die-cast aluminium, die-cast zinc, stainless steel, steel  
 Versions: Lift-off right/left, fixed, guide tabs, elongated holes, locking lever, detent, adjustable friction  
 Surfaces: Black, bright, blasted

### Product description:

Hinges are used in furniture and traditional machine construction as well as on other equipment, where they are mounted on doors, hatches and hoods, etc. Classic hinges are available made from plastic, aluminium, steel, sheet metal and stainless steel.

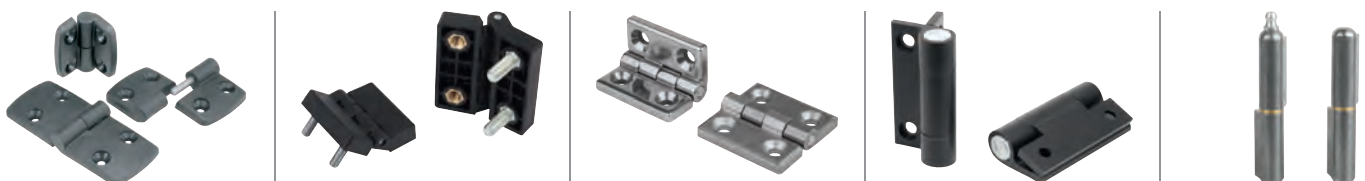



## Levelling feet



### Product versions:

Thread Ø:	M10–M30
Thread length:	15–225 mm
Height:	7–32 mm
Plate Ø:	28.5–120 mm
Load rating:	1.5–55 kN
Materials:	Steel, stainless steel, plastic
Versions:	With hexagon or knurled base, with hole, height-adjustable, Hygienic DESIGN
Surfaces:	Galvanised, bright, painted yellow, black

### Product description:

Levelling feet provide an easy way of counteracting any unevenness in the floor. They are used for alignment purposes to ensure that the equipment is installed securely. Levelling feet are available with vibration absorption and structure-borne sound absorption.



## Threaded spindles



### Product versions:

Thread Ø:	M6–M24
Thread length:	15–200 mm
Materials:	Steel, stainless steel
Versions:	Bright, black oxidised, blue passivated
Surfaces:	Black

### Product description:

Threaded spindles are required as components for assembling swivel feet and levelling feet. Depending on the application, the threaded spindles may need to be coordinated with the plates. If desired, threaded spindles and plates can be ordered pre-assembled.



## Plates



### Product versions:

- Plate Ø: 30–175 mm
- Load rating: 0.2–55 kN
- Materials: Steel, stainless steel, die-cast zinc, plastic
- Versions: Antistatic, with extension, with vibration absorption, with rubber base
- Surfaces: Bright, galvanised, black

### Product description:

Plates, like threaded spindles, are also required as components for assembling levelling and swivel feet. Plates and threaded spindles can be combined in any configuration. The extra anti-slip plate absorbs vibrations and prevents the foot slipping, making it more stable.



## Levelling feet accessories



### Product versions:

- Materials: Steel, stainless steel, plastic
- Versions: Thrust pads, thrust spindles, ball joints, tube inserts, caps
- Surfaces: Bright, black oxidised, black

### Product description:

Possible accessories for levelling feet include caps for the feet that protect against scratch marks and tube inserts that act as a fastening element.



## Tube connectors



**Product versions:**

Diameter:	12–50 mm
Square bar:	25–40 mm
Materials:	Aluminium, stainless steel, plastic
Versions:	Cross, angle, foot, flange, swivel, joint, linear actuators
Surfaces:	Black, vibratory ground, polished

**Product description:**

Tube connectors are ideal for assembling round and square profiles. A suitable clamping lever for fastening can be supplied on request.



## Square tube connectors



**Product versions:**

Sizes:	20–30 mm
Materials:	Plastic
Versions:	Connecting block, two-way, star, joint
Surfaces:	Black

**Product description:**

Square tube connectors are ideal for assembling square profile constructions.

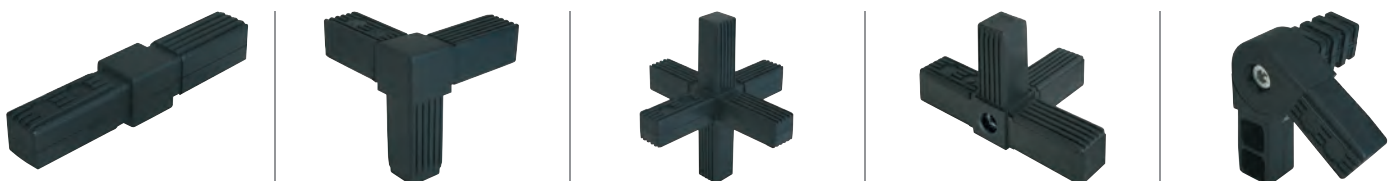

## Round tubes and square tubes



### Product versions:

Diameter:	12–50 mm
Square bar:	20–40 mm
Length:	500–2000 mm
Materials:	Steel, aluminium
Surfaces:	Galvanised, light anodised

### Product description:

The manufacturing tolerances of the round and square tubes match the specific tube connectors.



## Profile connector accessories



### Product versions:

Materials:	Steel, die cast zinc, plastic,
Versions:	Straps, angle sets, clamping angles, joints, covers, cable holders
Surfaces:	Bright, black

### Product description:

The answer to connecting, clamping and holding aluminium profiles. All components are a perfect match for modern profiles with 8 mm or 10 mm slot widths.





## Tube connector accessories



### Product versions:

Diameter:	12–50 mm
Square bar:	20–40 mm
Materials:	Plastic, steel
Versions:	Reducing bushing, round/square tubes, press-in plugs
Surfaces:	Black, galvanised

### Product description:

This includes components such as reducing bushings for round and square tubes as well as press-in plugs.



## Telescopic slides



19"



### Product versions:

Length:	200–1100 mm
Travel:	140–1100 mm
Load capacity per pair:	10–130 kg
Materials:	Steel, stainless steel
Versions:	Galvanised, light anodised

### Product description:

Telescopic slides are used in drawers and pull-out systems. They are easy to handle and offer a great deal of stability. They are available with partial, full and over-extension.





## Latches



### Product versions:

Retaining force N:	500–30,500 N
Materials:	Steel, stainless steel
Versions:	With spring clip, draw bail, release, adjustable
Surfaces:	Galvanised, blue passivated, bright

### Product description:

Latches are used as simple locks for covers, cladding and containers in machine, plant and container construction. The clamping stroke exceeds the dead centre point, which makes them able to withstand vibrations.



## Toggle clamps



### Product versions:

Hand force N:	80–290 N
Retaining force N:	250–15,000 N
Clamping force N:	170–3900 N
Materials:	Steel, stainless steel
Versions:	Horizontal, vertical, with safety interlock
Surfaces:	Black, bright
Grip colour:	Black, red, orange

### Product description:

Toggle clamps are intended for assembly and clamping fixtures and are used in machine construction, metalworking and woodworking. Due to their slim design, toggle clamps can be easily integrated into tight spaces.





## Toggle clamp latches / toggle clamp hooks



### Product versions:

Hand force N:	80–600 N
Tractive force N:	1500–19,000 N
Retaining force N:	2000–40,000 N
Materials:	Steel, stainless steel
Versions:	Horizontal, vertical, with catch plate
Surfaces:	Galvanised, chromed, bright
Grip colour:	Red, orange

### Product description:

Toggle clamp latches and hooks are ideal as an assembly and clamping fixture for quick closing and fastening of lids and hatches.



## Push-pull toggle clamps



### Product versions:

Hand force N:	80–200 N
Retaining force N:	500–50,000 N
Clamping force N:	500–7000 N
Materials:	Steel, stainless steel, ductile cast iron
Versions:	With/ without mounting bracket, mini
Surfaces:	Galvanised, chromed, phosphated
Grip colour:	Blue, orange

### Product description:

Push-pull toggle clamps act as an assembly and clamping fixture in machine construction and metalworking. As push-pull toggle clamps lock in both closed and open positions, they can be operated by either pushing or pulling.

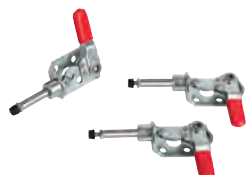

## Pneumatic clamps



### Product versions:

Retaining force N:	1000–25,000 N
Clamping force N:	800–8000 N
Operating pressure in bar:	2–6 bar
Materials:	Steel, cast steel
Versions:	Horizontal, vertical
Surfaces:	Galvanised, chromed, black oxidised, phosphated

### Product description:

Pneumatic clamps are especially suitable for metalworking and woodworking. Due to the fact they are easy to operate, they are ideal for automated, efficient and quick clamping tasks. The pneumatic cylinder is available with double-action function without end position damping.



## Toggle clamp accessories



### Product versions:

Materials:	Steel, plastic, aluminium
Versions:	Plastic grips, clamping spindles, angle brackets, nuts, thrust pads, protective caps, thrust screws, adapter block, adapter plate
Surfaces:	Black, orange, galvanised, chromed

### Product description:

Accessory parts are used to replace or add to individual components.



## Clamping units



### Product versions:

Materials: Steel, cast iron, aluminium  
 Versions: Clamp straps, clamp strap units, riser blocks, connecting screws, thrust pads  
 Surfaces: Black, green, galvanised

### Product description:

Clamping units are used to clamp workpieces. Various types are available.



## Clamp straps



### Product versions:

Materials: Steel  
 Versions: Pin-end clamping, offset, double-sided, movable  
 Surfaces: Black

### Product description:

Clamp straps used in machine and fixture construction and in toolmaking are used to clamp workpieces and components. They are very versatile, made of carbon steel and are available in various designs.



## Hook clamps



### Product versions:

Materials: Steel  
 Versions: With protective insert, elongated clamp strap unit, with collar, with mounting bracket, ground, hook clamp holder  
 Surfaces: Bright

### Product description:

Notable features of the hook clamps are that they can be used in a wide range of applications and do not require much space. For example, they can be used in the construction of machines, tools and fixtures.



## Swing clamps



### Product versions:

Clamping force N: 800–6000 N  
 Hand force N: 100–600 N  
 Materials: Steel, cast iron  
 Versions: Heavy, mini, pneumatic  
 Surfaces: Black, green

### Product description:

Swing clamps are used where the clamping points must be free when the workpiece is loaded or removed. They are actuated manually or pneumatically. They are predominantly used in machine construction, fixture construction and toolmaking. They can be installed either horizontally or vertically.



## Pull and thrust clamps



### Product versions:

Clamping force N:	900–8000 N
Retaining force N:	2000–14,000 N
Materials:	Steel
Versions:	Heavy, pneumatic, actima clamping element, clamping pin, clamping screw
Surfaces:	Black, bright

### Product description:

Pull clamps and thrust clamps are suitable for simultaneously clamping and positioning workpieces. They are actuated manually or pneumatically. Different types can be mounted either horizontally or vertically.



## Side clamps



### Product versions:

Clamping force kN:	3–46 kN
Materials:	Steel, cast
Versions:	With rest pad, with support, with riser
Surfaces:	Black

### Product description:

Some side clamps hold workpieces in place by rotating a spiral cam which exerts pressure on the swivel jaw, simultaneously producing a positive down force.



## Toe clamps



### Product versions:

Clamping force kN:	2–40 kN
Tightening torque Nm:	2.7–200 Nm
Materials:	Steel
Versions:	Adjustable, stepped, flat clamps, rack plates, toe clamps
Surfaces:	Black

### Product description:

Toe clamps have a positive down force. Their low height prevents protruding edges.



## Notes

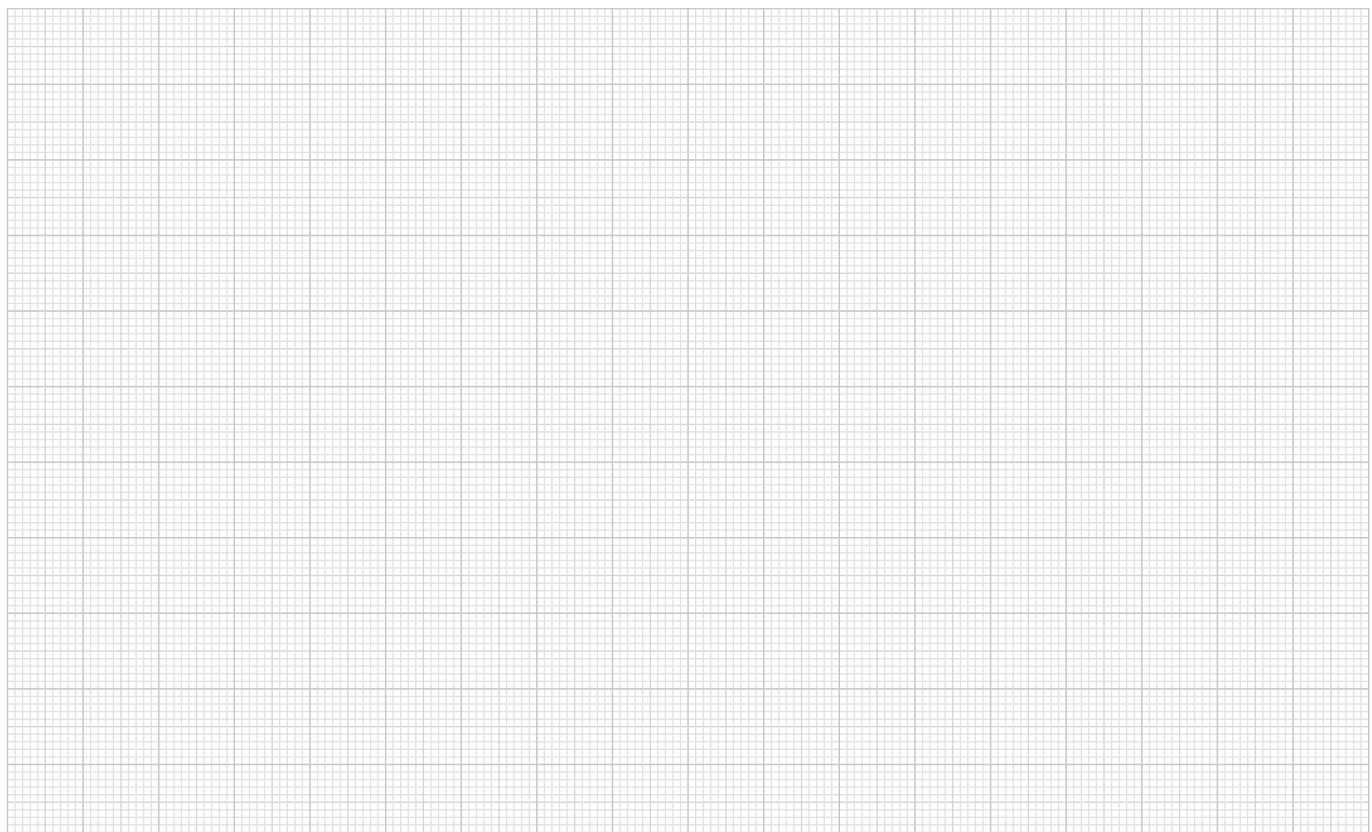



## Wedge clamps



### Product versions:

Thread Ø:	M4–M16
Clamping range min.–max.:	12.3–13.1 mm to 101.6–103.9 mm
Clamping force kN:	11–60 kN
Tightening torque Nm:	3–210 Nm
Materials:	Steel, aluminium profile
Versions:	Double, machinable
Surfaces:	Black, anodised

### Product description:

Wedge clamps are suitable for clamping both single and multiple workpieces. Their compact design allows space-saving series clamping.



## Cam clamps



### Product versions:

Materials:	Steel
Versions:	Single, double, with end clamping, central clamping
Surfaces:	Black

### Product description:

In machine construction, fixture construction and toolmaking, cam clamps enable fast and torque-free clamping that makes it impossible for the levers clamping motion to exceed the maximum clamping force. Cam clamps with end or central clamping are available. No additional tools are required.





## Centring clamps



### Product versions:

Clamping force kN:	0.5–45 kN
Tightening torque Nm:	0.7–650 Nm
Materials:	Steel, stainless steel
Versions:	With balls, hexagon, internal thread, external thread, mandrel collet, shaft clamping units
Surfaces:	Black, bright

### Product description:

These centring clamps allow workpieces to be centred on and clamped in a bore. The advantages of centring clamps include precise self-centring, distortion-free clamping and a low overall height.



## Spring plungers



### Product versions:

Outside diameter:	M3–M24, Ø 2.5–Ø 16 mm
Length:	4–80 mm
Travel:	0.4–40 mm
Starting spring force N:	0.4–95 N
Final spring force N:	2.5–240 N
Materials:	Steel, stainless steel
Versions:	Hexagon socket, slot, with head, proximity switch, across flats, with ball, with thrust pin
Surfaces:	Black, bright

### Product description:

Spring plungers are used for indexing, positioning and fixing components. As they are extremely versatile and easy to install, spring plungers are used in machine construction, crafts and in the household.

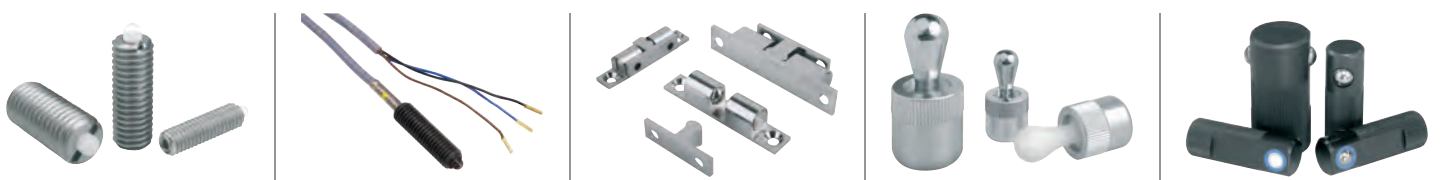

## Indexing plungers



### Product versions:

Pin diameter: 3–25 mm  
 Outside diameter: Ø 5–Ø 50 mm, M6–M24  
 Length: 10–106 mm  
 Travel: 3.5–44 mm  
 Materials: Steel, stainless steel, plastic  
 Versions: Hardened, unhardened, with locking mechanism, with thread lock, short version, with elongated indexing pin, with five lobe grip, with markings, without collar, pneumatic, Premium with conical pin  
 Surfaces: Black, red, bright

### Product description:

Indexing plungers facilitate fast indexing and locking of moving components. Mushroom grips makes them easy to operate.



## Ball lock pins



### Product versions:

Pin diameter: 5–46 mm  
 Length: 10–100 mm  
 Shearing force double shear kN: 22–258 kN  
 Materials: Steel, stainless steel  
 Versions: L-grip, T-grip, with mushroom knob, with bracket, without head, with axial lock, adjustable grip, with twist knob, with twist lock  
 Surfaces: Black, bright

### Product description:

Ball lock pins are used to join and fasten machine parts and workpieces quickly and easily. The axial lock is released by pressing the push button.



## Cam-action indexing plungers



### Product versions:

Pin diameter: 4–10 mm  
 Length: 38–70 mm  
 Travel: 6–12 mm  
 Materials: Steel, stainless steel  
 Versions: Bright, with stop  
 Surfaces: Black, bright

### Product description:

Cam action indexing plungers can be used for all types of locking and fixating mechanisms, especially where the indexing pin must not be allowed to protrude. The lock is released by turning the grip 180°.



## Retaining cables / ball chains



### Product versions:

Length: 100–1000 mm  
 Materials: Steel, stainless steel, aluminium  
 Versions: With loop, with crimp terminal, with key ring, safety spiral cable, key rings  
 Surfaces: Black, bright

### Product description:

Retaining cables and ball chains are used to secure components. They are available with a loop or key ring.

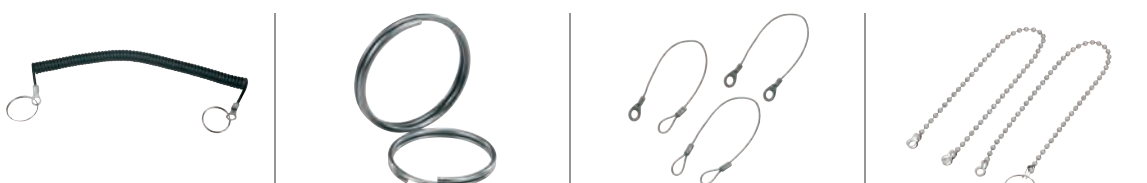

## Indexing plunger accessories



**Product versions:**

**Materials:** Steel, stainless steel, aluminium  
**Versions:** Bushes, spacer rings, mounting brackets, double-ended ring spanners, locating bushes, ball lock bushes, locking pins, pin  
**Surfaces:** Black, bright

**Product description:**

Accessories include products such as bushes, mounting brackets and spacer rings.



## Spring plunger accessories



**Product versions:**

**Versions:** Supports, angle brackets, riser plates, ball catches, magnetic catches, assembly keys, assembly tools, locators

**Product description:**

Assembly tools that make installation easier.





## Ball lock pin accessories



### Product versions:

Materials: Steel, stainless steel  
 Versions: Locating bushes, ball lock bushes with and without twist lock, magnetic bushes, locking pins, pins  
 Surfaces: Bright, nickel plated, tempered

### Product description:

Accessories include products such as bushes for ball lock pins.



## Self-aligning pads / thrust screws

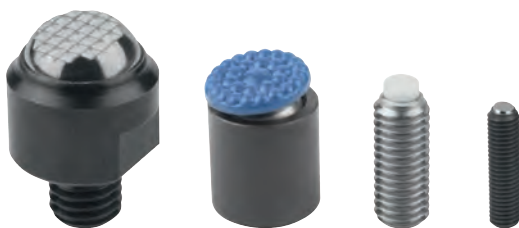

### Product versions:

Support diameter:  $\emptyset$  10– $\emptyset$  24 mm, M3–M24  
 Ball diameter: 10–40 mm  
 Load rating kN: 0.3–220 kN  
 Ball: Flattened, flat, with serrations, with diamond surface, with polyurethane surface  
 Inserts: POM, carbide, stainless steel  
 Materials: Steel, stainless steel  
 Versions: With 12°, 14° or 20° swivel angle, with O-ring, replaceable inserts, self-righting, adjustable, hexagon socket, ball-end thrust screws with head, without head, thrust screws  
 Surfaces: Black, bright

### Product description:

Self-aligning pads are used as supports, stops and thrust pads in machine construction, fixture construction and installation. In addition, they are used to support and clamp workpieces.



## Inserts

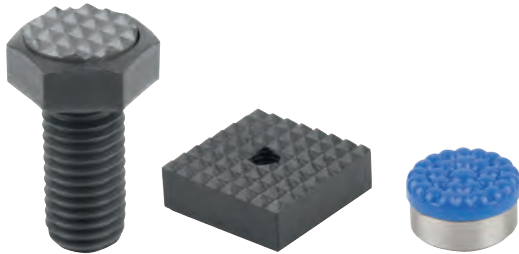

### Product versions:

Diameter:	Ø 10–25 mm, M6–M20
Height:	10–12 mm
Length:	25–60 mm
Materials:	Steel, stainless steel, POM
Versions:	Round, square, adjustable, hexagonal
Surfaces:	Black, white, bright

### Product description:

Inserts are an important component for installing into clamping arms, clamping fixtures, jaw plates and self-aligning pads. They transfer very high torque values and above average retaining forces.



## Locating pins / rest pads



### Product versions:

Mount diameter:	Ø 5–Ø 50 mm, M6–M20
Length:	4–50 mm
Materials:	Steel, stainless steel, brass, aluminium
Versions:	With flattened ball-end, cylindrical positioning pins, free-milled, expanding locating pins, with internal thread, locating bushes, positioning feet, fixture feet, pin form with internal/external thread, with positioning pins, locating feet, support bolts, adjustable with locknut, stop screws, adjustable stops with end position feedback, movable clamp stop
Surfaces:	Black, bright

### Product description:

One of the uses of locating pins is to position workpieces and fixtures. A ball-end helps to ease the fastening process. Rest pads can be used as feet or supports for workpieces and fixtures, depending on the design.





## Height adjustment elements



### Product versions:

Thread Ø:	Ø 4.5–Ø 33 mm
Min. height:	15–105 mm
Max. height:	19–144 mm
Power kN:	40–323 kN
Materials:	Steel, stainless steel
Versions:	With locknut, low version, with spherical levelling washer, spherical washers, conical seats, spherical levelling washers
Surfaces:	Bright, blue passivated, galvanised

### Product description:

Height adjustment elements are intended for use in levelling and mounting motors, aggregates, drive units and assembly lines.



## Screws / nuts / washers



### Product versions:

Materials:	Steel, stainless steel
Versions:	Eye bolts, grub screws, studs, screws for T-slots, hexagon nuts, C-washers captive, shoulder screws, C-washers, T-thrust screws, cap nuts
Surfaces:	Black, bright, galvanised

### Product description:

Screws, nuts and plates can be used in a variety of applications.





## Threaded Inserts



### Product versions:

External thread: M8–M33  
 Thread length: 8–33 mm  
 Materials: Steel, stainless steel  
 Versions: Reinforced, solid bodies, self-locking internal thread, self-tapping, repair kit  
 Surfaces: Black, bright, galvanised

### Product description:

Threaded inserts are particularly quick and easy to install. They enable tapped holes which have been damaged to be repaired.



## Drill bushes



### Product versions:

Outside diameter:  $\varnothing$  3– $\varnothing$  62 mm  
 Length: 6–67 mm  
 Materials: Special low carbon steel  
 Versions: Cylindrical, with collar  
 Surfaces: Bright

### Product description:

Drill bushes help to guide the drill directly into the drilling jig. Using drill bushes simplifies and optimises the drilling process at the workplace.





## Connectors for profiles and profile systems

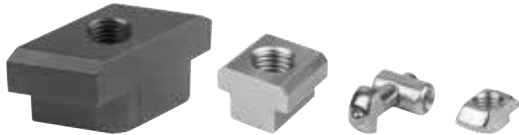

**Product versions:**

- Slot width: 6–10 mm
- Materials: Steel, die-cast zinc
- Versions: Nuts, parallel keys, hammer-head screws, connecting sets, fastening sets
- Surfaces: Bright, galvanised

**Product description:**

The answer to connecting, clamping and holding aluminium profiles. All components are a perfect match for modern profiles with 8 mm or 10 mm slot widths.



## Machine and fixture component accessories



**Product versions:**

- Materials: Steel, aluminium
- Versions: Shim plates, swing screws, clamping joints, multiple connectors, clevis joints, screw joints for dial gauges, sliding clamps
- Surfaces: Black, bright

**Product description:**

Slim plates, sliding clamps, clevis joints, clamping joints and swing screws.



## Handles



### Product versions:

Thread Ø: M6–M12  
 Length: 35–150 mm  
 Materials: Steel, stainless steel  
 Surfaces: Black grips, bright bar

### Product description:

Handles are available with various grip types and lengths.

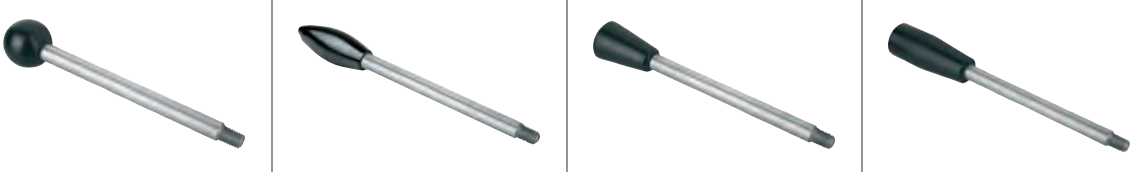

## Shaft collars / locking rings / clamp hubs



### Product versions:

Outside diameter: 7–140 mm  
 Inside diameter: 3–100 mm, M4–M20  
 Materials: Steel, stainless steel, aluminium  
 Versions: With wing grip, with clamping lever, with thread, threaded pin, one-piece, two-piece  
 Surfaces: Black, bright

### Product description:

Shaft collars and locking rings can be used as a position and stop element for shafts. In contrast, clamp hubs can turn and position shafts with the help of a handle.





## Joints



### Product versions:

Materials: Steel, stainless steel  
 Versions: Spherical seats, ball studs, rod ends, clevis joints, ball joints, axial joints, quick-fit couplings, splint pins, spherical bearings, rod-end eyes, snap-in pins, R-clips, circlips  
 Surfaces: Black, bright, galvanised

### Product description:

In machine construction, vehicle construction and transport technology, joints enable rotary movements, torque created by shafts, and forces to be transmitted and redirected. Alongside clevis joints, this group also includes quick-fit couplings, ball joints and axial joints.

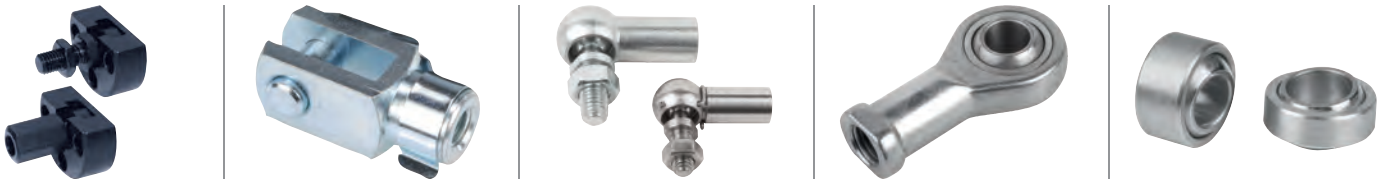

## Magnets raw

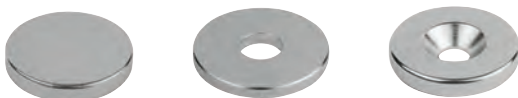

### Product versions:

Outside diameter: 3–56 mm  
 Length: 10–80 mm  
 Magnetic force N: 1.1–125 N  
 Materials: Neodymium, AlNiCo  
 Versions: Disc form, block form, bar form  
 Surfaces: Bright

### Product description:

Raw magnets are always an unshielded system. All of the magnet's surfaces exert magnetic force.

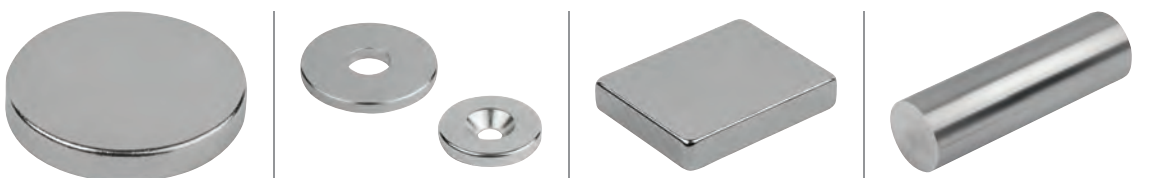

## Deep pot magnets



### Product versions:

Diameter:	Ø 6–Ø 65 mm
Length:	10–85 mm
Magnetic force N:	1.5–600 N
Materials:	Steel, brass
Versions:	Magnets, deep pot magnets, shallow pot magnets
Surfaces:	Bright, gold, red

### Product description:

Deep pot magnets have a core that is made of a permanent magnetic material. They are a shielded system. Deep pot magnets are easily removable, flexible, non-positive fasteners.



## Shallow pot magnets



### Product versions:

Diameter:	Ø 10–Ø 125 mm
Height:	4.5–26 mm
Magnetic force N:	4–1750 N
Materials:	Steel
Versions:	Magnets with external/internal thread, with counterbore, with hook, protective rubber caps
Surfaces:	Galvanised, black

### Product description:

Shallow pot magnets have a core that is made of a permanent magnetic material. They are a shielded system. Shallow pot magnets are easily removable, flexible, non-positive fasteners.



## Magnets with rubber protective jacket



### Product versions:

Diameter:	Ø 12–Ø 88 mm
Height:	6–20 mm
Magnetic force N:	10–420 N
Materials:	Steel
Versions:	Magnets with internal and external thread
Surfaces:	Black, bright

### Product description:

The magnet is encased in rubber, which helps to protect sensitive surfaces.



## Retaining magnets



### Product versions:

Diameter:	Ø 10.5–Ø 36 mm
Height:	7–9 mm
Magnetic force N:	0.7–10 N
Materials:	Plastic
Surfaces:	White, blue, red, black

### Product description:

The magnetic core inside retaining magnets is surrounded by a plastic coating. Their design makes them particularly suitable for use on noticeboards, whiteboards and thin metal sheets.

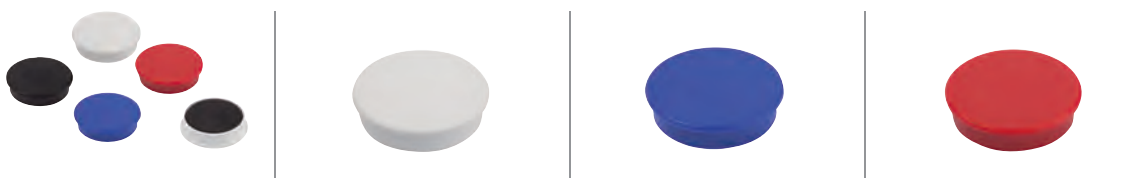

## Magnets button / horseshoe magnets



### Product versions:

Diameter:	Ø 13–Ø 32 mm
Width:	30–70 mm
Height:	10–41 mm
Magnetic force N:	7–320 N
Materials:	AlNiCo
Surfaces:	Red

### Product description:

This is an unshielded system with a two-part magnetic face. Magnet buttons and strong magnets are easily removable, flexible non-positive fasteners.

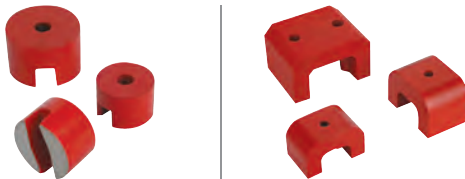

## Rubber buffers



### Product versions:

Outside diameter:	Ø 8–Ø 125 mm
Thread Ø:	M3–M16
Thread length:	6–42 mm
Thread depth:	3–12 mm
Height:	8–93 mm
Spring stiffness N/mm:	3.7–2240 N/mm
Load N:	17–20,000 N
Materials:	Steel, stainless steel
Versions:	Waisted, suction foot, parabolic, conical, spherical
Surfaces:	Black

### Product description:

Rubber buffers are intended to be used as a flexible buffer element and to reduce vibrations.





## Oil level sight glasses

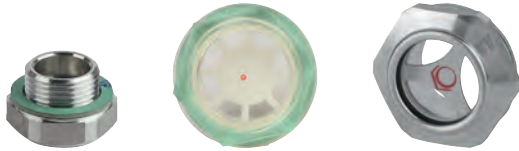

### Product versions:

Thread: G 1/4–G 2, M14–M40  
 Materials: Polyamide, aluminium  
 Versions: With/ without reflector, can be pressed in, can be screwed in, with glass window, with domed plate  
 Temperature resistance: 90–150°C

### Product description:

Oil level sight glasses are used in machine construction, vehicle technology and agricultural machinery.



## Screw plugs / press-in plugs



### Product versions:

Standard: DIN 906, DIN 908, DIN 910  
 Thread Ø: R 1/8–R 1 1/2, G 1/8–G 2, M8–M48  
 Materials: Steel, stainless steel, aluminium, plastic  
 Versions: With hexagon socket, with hex head, with symbols, with magnet, with dipstick  
 Surfaces: Black, black/red, red, bright

### Product description:

They are suitable for sealing containers. They are also used where a medium needs to be changed or emptied after a certain period of time.



## Filler necks



### Product versions:

Versions: For pressing in, for screwing on, with/ without chain, with filter, with air and vent valve  
 Materials: Plastic, steel  
 Surfaces: Black/red, chrome

### Product description:

Filler necks are predominantly used in machine construction, vehicle technology or agricultural machinery.



## Grease nipples



### Product versions:

Versions: Conical head, flush type, flat type, protective caps  
 Standard: DIN 71412, DIN 3404, DIN 3405  
 Thread Ø: R 1/8–R 1/4, G 1/8–G 3/8, M6–M16  
 Form: Hexagonal, square  
 Materials: Steel, stainless steel, polyethylene  
 Protective cap surfaces: Black, yellow, green, red

### Product description:

Grease nipples are used for applying a lubricant directly to a lubrication point. They are available as flush types, as flat types and in a conical form.

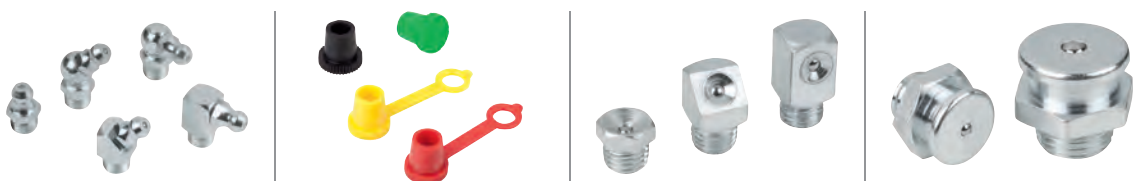

## Oil level gauges



### Product versions:

Versions:	With temperature scale, with reflector, long version
Housing materials:	Polyamide, steel, aluminium
Thermometer scale:	0–80°C, 0–100°C
Temperature resistance:	90–100°C
Pressure resistance:	1–10 bar

### Product description:

Oil level gauges are used to check the current fill level. They are also available with an electronic monitoring option. The oil level gauge is fitted directly into tapped holes or via two fastening holes.



## Vent screws



### Product versions:

Versions:	With filter, with splash guard, with check valve, with dipstick
Materials:	Polyamide 66, brass
Thread Ø:	G1/4–G1 1/2 / M16–M22
Surfaces:	Black/red, bright

### Product description:

Vent screws are used to prevent too much pressure building up in the container. A filter prevents oil escaping without negatively affecting the pressure balance.



## Scales

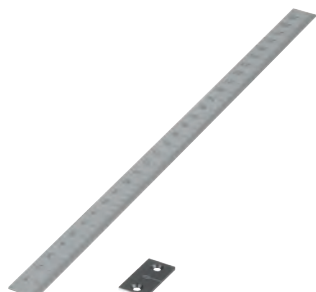

### Product versions:

Versions:	Self-adhesive, with fastening hole, zero mark, vernier scale
Materials:	Aluminium, stainless steel
Length:	250–1000 mm
Mounting position:	Horizontal, vertical
Surfaces:	Black, bright

### Product description:

Scales act as position indicators and help to obtain precise readings. They are attached using their self-adhesive back or by using holes.

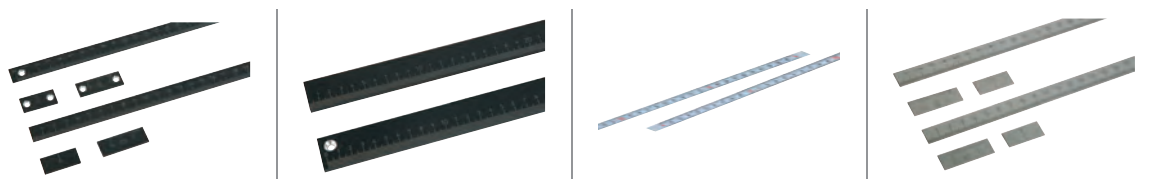

## Scale rings



### Product versions:

Material:	Steel
Versions:	Matt-finished chromed, scale marks and figures in black

### Product description:

Scale rings facilitate adjustment to an exact position.





## Level vials



### Product versions:

**Type:** For screwing on, with plastic frame, with bead-edged frame, with cylindrical frame, without frame, tubular bubble levels  
**Materials:** Brass, polymethylmethacrylate, stainless steel, aluminium, polyamide  
**Housing/frame Ø:** 12–34 mm  
**Versions:** Nickel plated and polished, black, ivory

### Product description:

Level vials are used as zero indicator instruments or for checking the horizontal position. They are available as bullseye and tubular bubble levels.



## Lifting rings



### Product versions:

**Type:** Ring bolts, ring nuts, swivel ring bolts, D-rings, shackles  
**Thread Ø:** M8–M36  
**Permissible load:** 0–8500 kg  
**Materials:** Steel, stainless steel  
**Versions:** 4x safety, plastic coated, forged, cast  
**Surfaces:** Bright, yellow, red

### Product description:

D-rings are used to lift and pull objects. The welding block and bracket are made of steel, a material which is ideally suited to welding. This makes the equipment easy to install.



## Ball transfer units



### Product versions:

Housing materials: Steel, stainless steel  
 Ball materials: Steel, stainless steel, POM  
 Housing Ø: 13–100 mm  
 Ball Ø: 4.8–57 mm  
 Versions: With steel plate housing, with solid steel housing, without housing, undersprung, with felt seal, without felt seal

### Product description:

Ball transfer units transport heavy and sensitive goods. The goods can be rotated, positioned and moved in all directions with minimal effort.



## Tools



### Product versions:

Materials: Tool steel, aluminium, plastic  
 Versions: NOVOnox hygienic tools, sockets, protective caps for combination, open-ended and ring spanners  
 Surfaces: Silver, black

### Product description:

The comprehensive toolkit in the NOVOnox hygienic product line contains special tools with matching protective inserts and caps. These have been designed specially for tightening and loosening surface-sensitive fastener elements. In addition, other protective caps, ring spanners, open-ended spanners and sockets are available.







CLAMPING TECHNOLOGY



## Clamping units



### Product versions:

Materials: Steel, cast, aluminium  
 Versions: Clamp straps, clamp strap units, riser blocks, connecting screws, thrust pads  
 Surfaces: Black, green, galvanised

### Product description:

Clamping units are used to clamp workpieces. Various types are available.



## Clamp straps



### Product versions:

Materials: Steel  
 Versions: Pin-end clamping, offset, double-sided, movable  
 Surfaces: Black

### Product description:

Clamp straps used in machine and fixture construction and in toolmaking are used to clamp workpieces and components. They are very versatile, made of carbon steel and are available in various designs.



## Hook clamps



### Product versions:

Materials:	Steel
Versions:	With protective insert, elongated clamp strap unit, with collar, with mounting bracket, ground, hook clamp holder
Surfaces:	Bright

### Product description:

Notable features of the hook clamps are that they can be used in a wide range of applications and do not require much space. For example, they can be used in the construction of machines, tools and fixtures.



## Swing clamps



### Product versions:

Clamping force N:	800–6000 N
Hand force N:	100–600 N
Materials:	Steel, cast
Versions:	Heavy, mini, pneumatic
Surfaces:	Black, green

### Product description:

Swing clamps are used where the clamping points must be free when the workpiece is loaded or removed. They are actuated manually or pneumatically. They are predominantly used in machine construction, fixture construction and toolmaking. They can be installed either horizontally or vertically.



## Pull and thrust clamps



**Product versions:**

Clamping force N:	900–8000 N
Retaining force N:	2000–14,000 N
Materials:	Steel
Versions:	Heavy, pneumatic, actima clamping element, clamping pin, clamping screw
Surfaces:	Black, bright

**Product description:**

Pull clamps and thrust clamps are suitable for simultaneously clamping and positioning workpieces. They are actuated manually or pneumatically. Different types can be mounted either horizontally or vertically.



## Side clamps



**Product versions:**

Clamping force kN:	3–46 kN
Materials:	Steel, cast
Versions:	With rest pad, with support, with riser
Surfaces:	Black

**Product description:**

Some side clamps hold workpieces in place by rotating a spiral cam which exerts pressure on the swivel jaw, simultaneously producing a positive down force.



## Toe clamps



### Product versions:

Clamping force kN:	2–40 kN
Tightening torque Nm:	2.7–200 Nm
Materials:	Steel
Versions:	Adjustable, stepped, flat clamps, rack plates, toe clamps
Surfaces:	Black

### Product description:

Toe clamps have a positive down force. Their low height prevents protruding edges.



## T-slot clamps



### Product versions:

Materials:	Steel, stainless steel
Versions:	Low-profile clamp, flat clamp
Surfaces:	Black, bright

### Product description:

T-slot clamps produce a positive down force when the workpiece is clamped. They are suitable for flat workpieces.

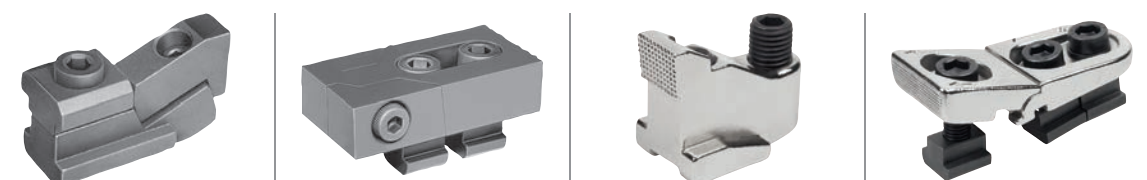

## Wedge clamps



### Product versions:

Thread Ø:	M4–M16
Clamping range min.–max.:	12.3–13.1 mm to 101.6–103.9 mm
Clamping force kN:	11–60 kN
Tightening torque Nm:	3–210 Nm
Materials:	Steel, aluminium profile
Versions:	Double, machinable
Surfaces:	Black, anodised

### Product description:

Wedge clamps are suitable for clamping both single and multiple workpieces. Their compact design allows space-saving series clamping.



## Centring clamps



### Product versions:

Clamping force kN:	0.5–45 kN
Tightening torque Nm:	0.7–650 Nm
Materials:	Steel, stainless steel
Versions:	With balls, hexagon, internal thread, external thread, mandrel collet, shaft clamping units
Surfaces:	Black, bright

### Product description:

These centring clamps allow workpieces to be centred on and clamped in a bore. The advantages of centring clamps include precise self-centring, distortion-free clamping and a low overall height.





## Locating elements



### Product versions:

Mount diameter:  $\emptyset 5$ – $\emptyset 50$  mm  
 Materials: Steel  
 Versions: Shoulder screws, removable locating pins, positioning units  
 Surfaces: Bright, black

### Product description:

Locating elements are suitable for positioning workpieces and fixtures. They enable a high degree of repeat accuracy when clamping workpieces.



## Rest and stop elements



### Product versions:

Materials: Steel, aluminium  
 Versions: Adjustable stops, locating supports, V-blocks vertical, V-block splits, extension columns, supports, seating blocks, inserts, grub screws with thrust pad, positioning units, workpiece supports, workpiece support cylinders, atlas jacks, 5D workpiece stops  
 Surfaces: Bright, black, blue

### Product description:

Support and stop elements are suitable for positioning, supporting and securing workpieces and fixtures. They enable a high degree of repeat accuracy when clamping workpieces.



## Form holding systems



### Product versions:

Materials: Steel, aluminium  
 Versions: Pneumatic, mechanical, external clamping, internal clamping, rectangular  
 Clamping range: 10 –140 mm  
 Milling depth: 1–25 mm

### Product description:

Form holding systems are used to clamp workpieces with asymmetrical contours. Systems with pneumatic and mechanical actuation are available. Two different collet types make it possible to clamp workpieces either externally or internally. A high degree of repeat accuracy is achieved due to the collet's precise positioning.

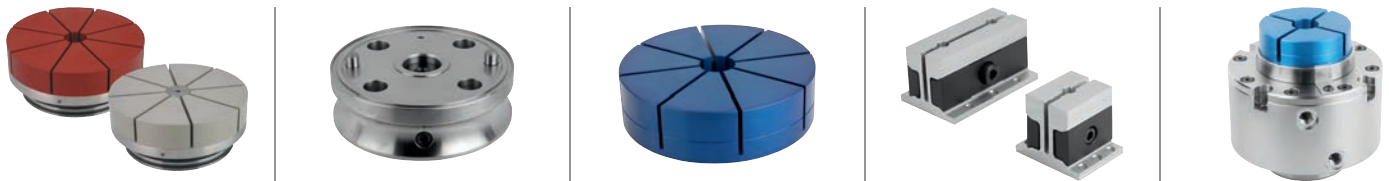

## Workpiece stabiliser



### Product versions:

Material: Steel  
 Versions: Extension shafts, fine adjustment, magnet, fastening sets, clamp strap unit, clamping balls with cup, workpiece stabiliser set with case  
 Surfaces: Black, bright  
 Clamping range: 255–1500 mm

### Product description:

The workpiece stabiliser has been developed specifically to minimise vibrations and oscillations when machining sensitive and thin-walled workpieces. This system is extremely flexible thanks to its different methods of fastening to the workpiece and the machine table.





## Fastener elements



### Product versions:

Materials:	Steel, stainless steel
Versions:	Tempered, black oxidised, case hardened, chromed, bright
Thread Ø:	M6–M36
Thread length:	10–400 mm

### Product description:

Fastener elements are used for positioning and securing elements. They are durable thanks to their hardened and tempered designs.



## Basic elements

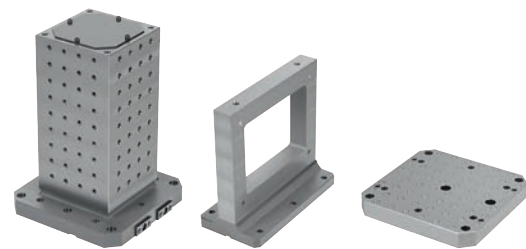

### Product versions:

Materials:	Grey cast iron
Tooling plates:	With/ without grid holes
Subplates:	With/ without grid holes
Tombstone:	With/ without grid holes
Tombstone cube:	With/ without grid holes
Tombstone one-sided:	With/ without grid holes, with T-slots
Grid holes:	D12F7/M12, D16F7/M16

### Product description:

Basic elements are essential for workpiece clamping structures. There are various grid system sizes available. They are suitable for all machine tools. Custom-made versions are available on request.



## Mineral cast



### Product versions:

Materials: Mineral cast with steel coating  
 Versions: Workholding tower, cross tombstone, plates, workholding pyramid  
 Grid holes: D12F7/M12

### Product description:

Mineral cast basic elements are used as an alternative to cast iron or steel versions. Due to their light specific weight (which is lighter than aluminium), they are ideal for use on machines with rapid traverse speeds.

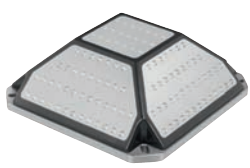

## Add-on elements



### Product versions:

Versions: Tombstones, mounting brackets, riser blocks, fastening blocks, precision riser blocks, round positioning plates  
 Materials: Cast iron, steel  
 Grid holes: D12F7/M12, D16F7/M16  
 Support height: 25–260 mm

### Product description:

Add-on elements are used as riser elements for clamping workpieces and fixtures. Elements of various heights and designs increase the flexibility of the clamping system.





## Modular clamping technology accessories



### Product versions:

Versions:	Locating sleeve, connecting blocks, locating pins, centring pins, locating bushes, protection plugs, tapped bushes
Materials:	Steel, aluminium
Thread Ø:	M12, M16
Inside diameter:	Ø 12–Ø 16 mm
Outside diameter:	Ø 20–Ø 50 mm

### Product description:

Accessories contain elements for connecting, positioning and securing objects. There is a wide variety of centring pins, shoulder screws, tapped bushes and locating bushes to choose from.



## Zero-point clamping systems



### Product versions:

Type:	UNI lock
Versions:	Clamping station 1x, 2x, 4x, 6x, installation clamp, double clamping module, manual clamping module, interchangeable subplates, clamping pins, quick-fit couplings
Materials:	Steel, aluminium
Retaining force N:	35,000–75,000 N
Support height:	50–150 mm
Number of clamping modules:	1x, 2x, 4x, 6x
Actuator:	Pneumatic/mechanical

### Product description:

The UNI lock zero-point clamping system enables quick and accurate clamping and referencing of fixtures and workpieces on all machine tools and machining centres. The pneumatic system clamps in a non-pressurised state. The key features of this system are its high retaining forces and high degree of repeat accuracy.





## 5-axis module clamping system 80



### Product versions:

Type:	UNI lock size 80
Materials:	Steel
Versions:	Basic module, baseplate, add-on clamping module, collet adapter, face grip adapter, reducer adapter, angle clamp adapter, T-slot centring clamp bolts, clamping pins, shoulder screws 50 kN
Retaining force kN:	35-75
Support height:	75-400 mm
Actuator:	Mechanical

### Product description:

The 5-axis modular clamping system 80 has been developed specifically for 5-side machining free from projecting edges. The workpieces can then be machined completely in a single clamping operation, guaranteeing a very high degree of repeat accuracy. As the modules are actuated mechanically, it is possible to achieve a high degree of clamping force.



## 5-axis module clamping system 50



### Product versions:

Type:	UNI lock size 50
Versions:	Basic module, advanced module, reducer adapter, clamping pins
Materials:	Steel
Retaining force kN:	20 - 30
Support height:	50-200 mm
Actuation:	Mechanical

### Product description:

The 5-axis modular clamping system 50 has been developed specifically for 5-side machining free from projecting edges. It is ideal for clamping smaller, complex workpieces. These can then be machined completely in a single clamping operation.





## 5-axis module clamping system 138



### Product versions:

Type:	UNI lock size 138
Materials:	Steel
Versions:	Basic module, baseplate, reducer adapter, clamping pins
Materials:	Steel
Retaining force kN:	100 kN
Support height:	50–250 mm
Actuator:	Mechanical

### Product description:

The 5-axis modular clamping system 138 has been developed specifically for 5-side machining free from projecting edges. It is ideal for clamping large, heavy workpieces. Each clamping module can tolerate loads of more than 10 tonnes. The workpieces can then be machined completely in a single clamping operation.



## Positioning systems and clamping systems



### Product versions:

Type:	Ball Lock, pneumatic positioning and clamping system
Versions:	Locating cylinder, locating bush, positioning bush
Materials:	Steel
Clamping plate thickness:	13–50 mm
Locating cylinder Ø:	13–50 mm
Actuation:	Mechanical / pneumatic

### Product description:

The positioning and clamping system allows precise positioning and fastening of tooling and baseplates. The mechanical or pneumatic system consists of a locating cylinder, centring bush and locating bush. The system is easy to self-assemble.







## 5-axis clamping system compact



### Product versions:

Type:	5-axis clamping system
Versions:	Jaw plate with pins, seating blocks, extensions, baseplates, pendulum jaws, centre jaws, cylinder clamping set, jaw pins, stop set, coupling for cross-clamping, clamping claw set
Materials:	Steel
Jaw width:	125 mm and 90 mm
Clamping width:	20–320 mm (20–1000 mm)
Clamping height:	150 mm (+ seating ledges)
Baseplate length:	400 mm, 280 mm

### Product description:

The 5-axis compact clamping system features a new kind of clamping technology. Its pull-down effect, combined with the clamping force applied directly on the workpiece, makes it particularly impressive. The system has been specifically designed for optimised machining of workpieces on modern 5-axis machines.



## 3-axis clamping systems / 5-axis clamping systems

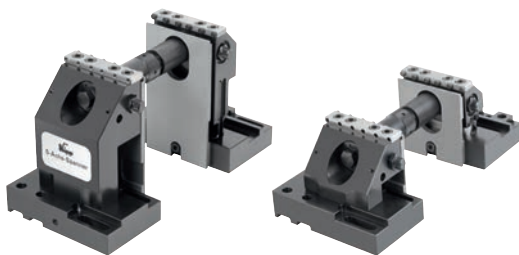

### Product versions:

Type:	3-axis clamping system, 5-axis clamping system
Versions:	Riser plates, seating blocks, draw-down jaws, jaw adapters for round workpieces, extension shaft jaw pins, stop set
Materials:	Steel
Clamping width:	22–236 mm (22–1000 mm)
Clamping height:	100, 105, 125, 150, 175, 200, 225, 250 mm
Jaw width:	100 mm
For grid spacing:	40 mm, 50 mm
For grid holes:	D12F7/M12, D16F7/M16
For slot spacing:	63, 80, 100, 125 mm

### Product description:

The 5-axis clamping system enables machining free of protruding edges and vibration, with extremely high cutting and feed forces. It enables the use of extremely short tools in order to guarantee the required tolerances and finishes. It can vary in height from 100 to 250 mm.



## Centric vices

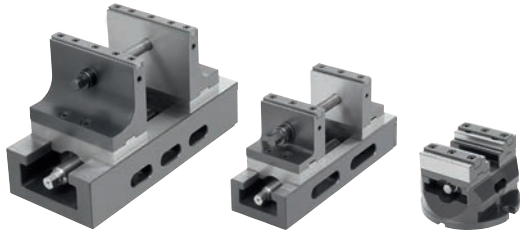

### Product versions:

Type:	Centric vice
Versions:	Attachment jaw, stepped, for 5-axis machining
Materials:	Steel
Jaw width:	65 mm, 80 mm, 125 mm
Baseplate length:	113 mm, 202 mm, 316 mm
Clamping range:	0–55 mm, 6–161 mm, 6–276 mm

### Product description:

Centric vices are especially suitable for clamping tasks in which workpiece clamping is positioned centrally. Centric vices are equipped with an interface for zero-point clamping systems, an interface for handling systems (suitable for automation) and an adapter plate for grid systems as standard.



## NC vices

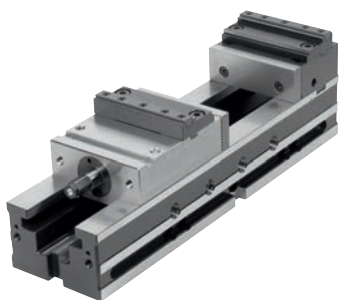

### Product versions:

Type:	NC vice
Versions:	Draw-down jaws, attachment jaw, stepped, prism jaws, angle drives
Materials:	Steel
Jaw width:	125 mm
Clamping range:	0–239 mm
Baseplate length:	470 mm
Overall length:	Max. 564
For slot spacing:	63 mm and 100 mm

### Product description:

NC vices are highly versatile pieces of equipment in clamping tasks. As the clamping range can be pre-adjusted quickly using a locking pin, the NC vice can be modified to fit various workpiece sizes in a short time. A wide variety of jaw plates ensures that the workpiece can be placed in the ideal clamping position.





## Multi-clamping system

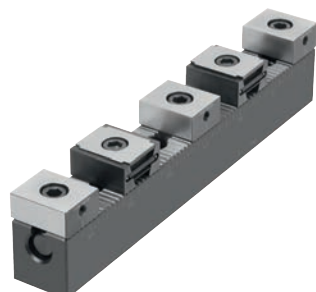

### Product versions:

Type:	Multi-clamping system
Versions:	Hard stops, soft stops, wedge clamp, stops, base rails, seating blocks, round slot keys
Materials:	Steel
Thread Ø:	M8, M12, M16
Fastening hole:	12H6, 12F7, 16F7
Length:	199 mm, 349 mm
Width:	24 mm, 48 mm

### Product description:

This clamping system can be used to clamp a number of workpieces at the same time. This makes it suitable for larger batch sizes. Different elements, such as base rails, stops and wedge clamps, make it possible to clamp workpieces of various sizes.

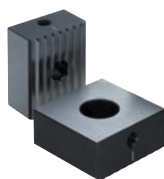
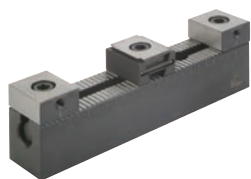



SPECIAL SOLUTIONS

# SPECIAL SOLUTIONS

HEINRICH KIPP WERK has extensive production resources. This is why we can produce special-solution construction groups and single items at any time that exactly suit customer specifications.

### Cam-action indexing plunger:

The engagement element was specially developed for the height adjustment of a tool carrier system.

Stainless steel version in A4 quality.

### Indexing plunger:

This is a special positioning part for machine construction.

The turned parts (sleeve and pin) are made of high-tensile, hardened steel. The aluminium mushroom knob is blue anodised.

### Tension lever:

This special coloured version of the grip is used on medical equipment. It is marked with 3D icons to suit the function.

Ergonomics and design guarantee an optimal match to the control panel interface.

In our machine shop are metal cutting, injection moulding and zinc die-casting machines.

Our own R&D department and toolmaking workshop ensure a professional implementation of special projects.

Completely assembled and, if desired, with treated surface.

Technicians accompany every single project - from offer preparation to feasibility assessment and through to completion.



Development/Design

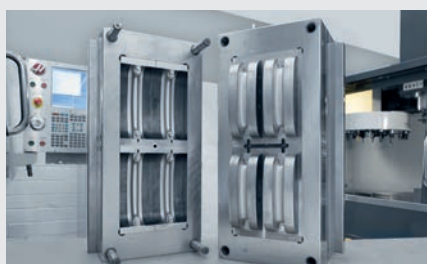

Toolmaking

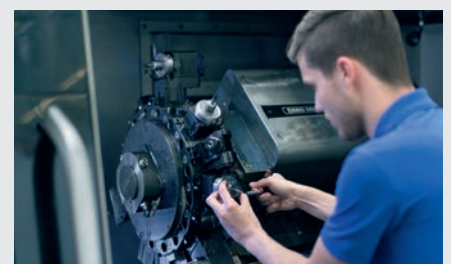

Machining



Zinc die-casting



Plastic injection moulding



Surface treatment



Assembly



The standard terms and conditions of sale, delivery and payment that you can find on our website **www.kipp.com** apply.

**HEINRICH KIPP WERK GmbH & Co. KG**

Postbox 11 60  
DE-72168 Sulz a. N.

Tel.	+49 7454 793-0
Fax	+49 7454 793-7982
Internet	<a href="http://www.kipp.com">www.kipp.com</a>
E-Mail	<a href="mailto:sales@kipp.com">sales@kipp.com</a> <a href="mailto:spanntechnik@kipp.com">spanntechnik@kipp.com</a>







**HEINRICH KIPP WERK GmbH & Co. KG**

Heubergstraße 2

72172 Sulz am Neckar

GERMANY

Tel. +49 7454 793-0

Fax +49 7454 793-7982

[info@kipp.com](mailto:info@kipp.com)

[www.kipp.com](http://www.kipp.com)



WEIßENPR 1904